



Marine Diesel Engine V180TI

- Compact Design
- Excellent Performance
- Low Fuel Consumption
- Easy Maintenance



- Rating output
 - 603kW (820PS)
- Displacement
 - 18,273cc
- Dimension (L×W×H)
 - 1,815×1,227×1,576mm
 - Without Reduction Gear

**Doosan Infracore
Engine**

Main Specification

Model	Units	V180TI (D2840LB)		
		V180TIH	V180TIM	V180TIL
Engine type		4cycle, V type, direct-injection, water cooled with turbo charger & inter-cooler		
Rating output	PS(kW) / rpm	600(441)/1,800	650(478)/2,100	820(603)/2,300
Displacement	c c	18,273		
Cylinder number - bore x stroke	mm	10 - 128 x 142		
Flywheel housing & fly wheel		SAE 1 & 14		
Low idling rpm	rpm	725 ± 25		
No load max. rpm	rpm	below 2,070	below 2,415	below 2,645
Compression ratio		15 : 1		14.6 : 1
Firing order		1 - 6 - 5 - 10 - 2 - 7 - 3 - 8 - 4 - 9		
Governor type of injection pump		Mechanical variable speed (R.Q.V)		
Fuel consumption(only Ref.)@ rated power	g / PS.h	150	156	158
	Lit / h	109	122	156
Starting system		Electric Starting by starter motor		
Starter motor capacity	V - kW	24 - 6.6		
Alternator capacity	V - A	24 - 50		
Battery	V - Ah	24 - 200		
Cooling system		Indirect sea water cooling with heat exchanger		
Cooling water capacity	Max. / Min.	lit 92 / 81		
Fresh water pump type		Centrifugal type, driven by belt		
Sea water pump type		Bronze impeller type driven by belt		
Lubricating oil(Engine)	Pan capacity	lit	Max : 35, Min : 28 (Engine total : 38)	
	Pressure	kg/cm ²	Full : 3.5, Idle : 1.2	
Direction of revolution	Crankshaf	Counter clockwise viewed from stern side		
Engine Size(L x W x H)	Without M/G	mm	1,815 x 1,227 x 1,576	
Engine dry weight	Without M/G	kg	1,550	1,630

H : Heavy Duty, M : Medium Duty, L : Light Duty

Engine Dimension

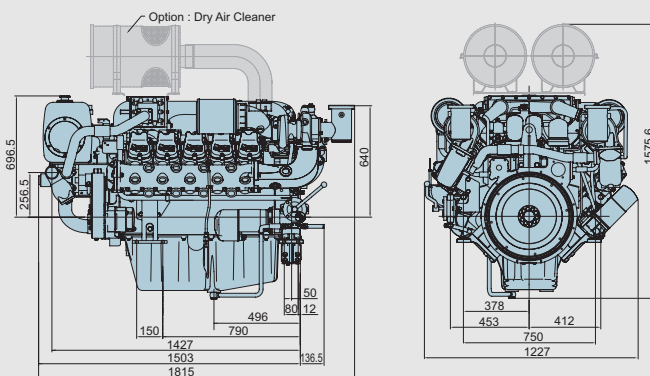

Performance Curve

- Heavy duty : 441kW(600PS)@1,800rpm
- Medium duty: 478kW(650PS)@2,100rpm
- Light duty : 603kW(820PS)@2,300rpm

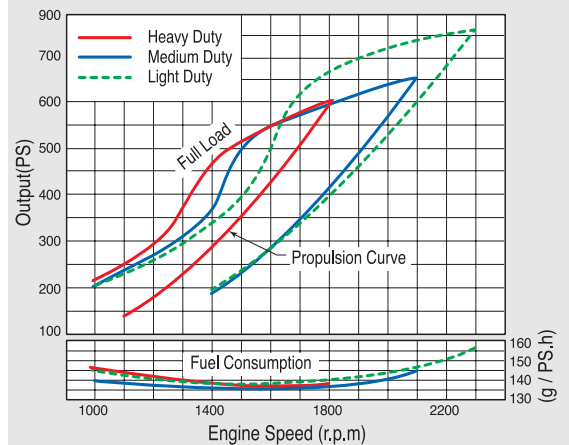

Marine rating to ISO 3046

(1) Heavy Duty

Operation hours are unlimited per year, at average load is up to 90 %, at full load is up to 80 %
 Typical gearbox ratio: 2.5 ~ 6
 (Fishing trawler, Tug boat, Pushing vessel, Cargo boat, Freighter, Ferry)

(2) Medium Duty

Operation hours are up to 3,000 per year, at average load is up to 70 %
 At full load is (up to 30 % / 4hrs per 12 hour operation period)
 Typical gearbox ratio: 2 ~ 3.5
 (Fishing trawler, Pilot boat, Escort boat, Passenger boat, Freighter, Ferry, Cruising vessel)

(3) Light Duty

Operation hours are up to 1,000 per year, at average load is up to 50 %
 At full load is (up to 20 % / 2hrs per 12 hour operation period)
 Typical gearbox ratio: 1 ~ 2.5
 (Light weight fishing boat, Yacht, Cruising vessel, Fast boat, Fire pump)

(Nov.2012)

AUTHORIZED DEALER

Doosan Infracore Engine

21/F, Doosan Tower, 18-12, Euljiro 6-ga,
 Jung-gu, Seoul, 100-730, Korea.
 Tel : 82 2 3398 8400
 Fax : 82 2 3398 8509
 Email : doosanmarine@doosan.com
 http://engine.doosaninfracore.co.kr

* Specifications are subject to change without prior notice.