

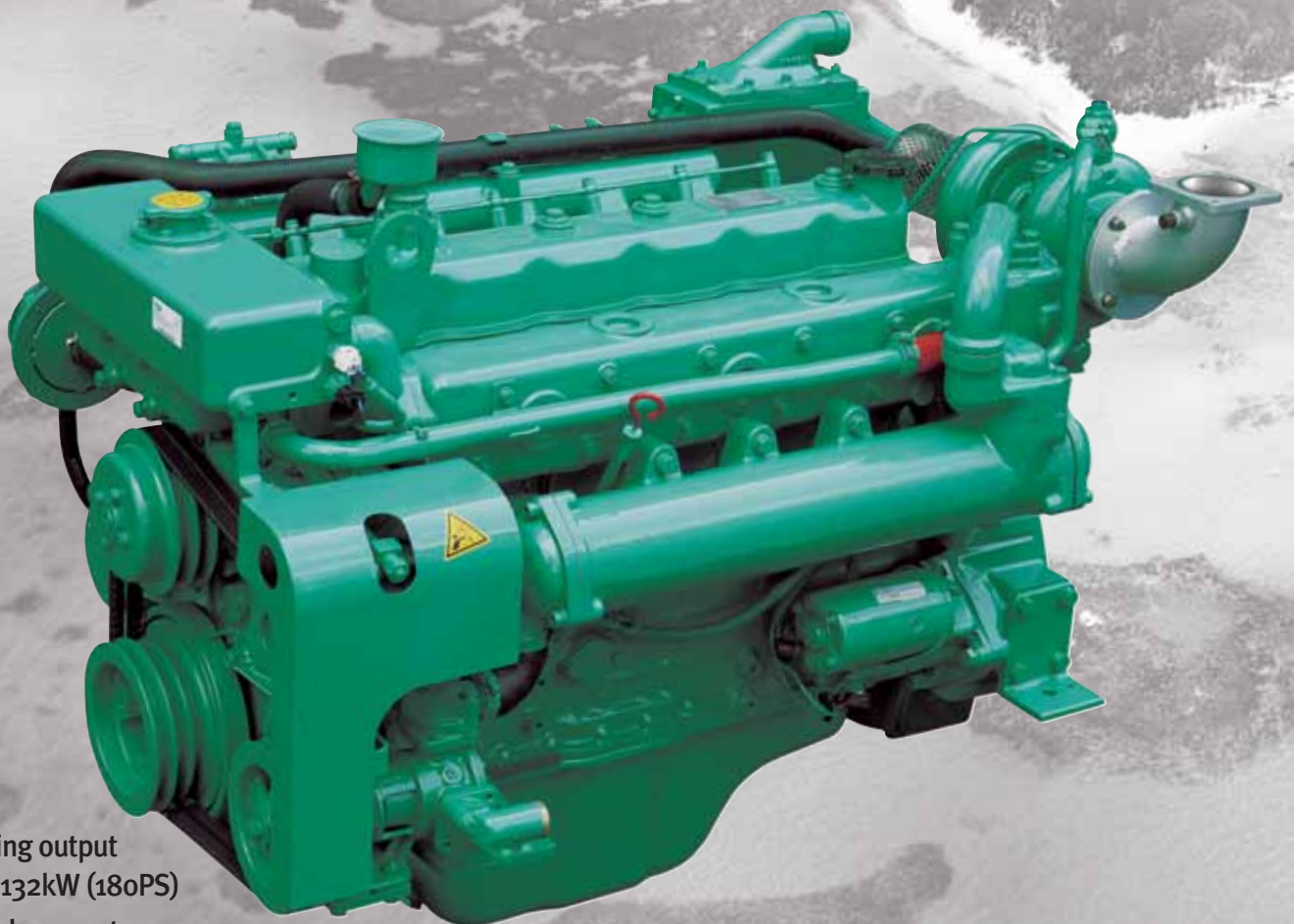

# Marine Diesel Engine L066TI

- Compact Design
- Excellent Performance
- Low Fuel Consumption
- Easy Maintenance



- Rating output
  - 132kW (180PS)
- Displacement
  - 5,785cc
- Dimension (L × W × H)
  - 1,352 × 800 × 917mm
  - Without Reduction Gear

**Doosan Infracore**  
Engine

## Main Specification

Model	Units	L066TIH	
Engine type		4cycle, In line, direct-injection, water cooled with turbo charger & inter-cooler	
Rating output	PS(kW) / rpm	180(132)/2,200	
Displacement	cc	5,785	
Cylinder number - bore x stroke	mm	6 - 102 x 118	
Flywheel housing & fly wheel		SAE 3 & 11 1/2	
Low idling rpm	rpm	750 ± 25	
No load max. rpm	rpm	below 2,420	
Compression ratio		19.5 : 1	
Firing order		1 - 5 - 3 - 6 - 2 - 4	
Governor type of injection pump		Mechanical all speed (R.S.V)	
Fuel consumption(only Ref.)@ rated power		g / PS.h	159
	liter/h	34.5	
Starting system		Electric Starting by starter motor	
Starter motor capacity	V - kW	24 - 4.5	
Alternator capacity	V - A	24 - 45	
Battery	V - Ah	24 - 100	
Cooling system		Indirect sea water cooling with heat exchanger	
Cooling water capacity	Max. / Min.	lit	25 / 20
Fresh water pump type		Centrifugal type, driven by V-belt	
Sea water pump type		Rubber impeller type driven by V-belt	
Lubricating oil(Engine)	Pan capacity	lit	Max : 19, Min : 14 (Engine total : 21)
	Pressure	kg/cm <sup>2</sup>	Full : 3.5, Idle : 1.0
Direction of revolution	Crankshaft	Counter clockwise viewed from stern side	
Engine Size(L x W x H)	Without M/G	mm	1,352 x 800 x 917
Engine dry weight	Without M/G	kg	535

H : Heavy Duty, M : Medium Duty, L : Light Duty

## Engine Dimension

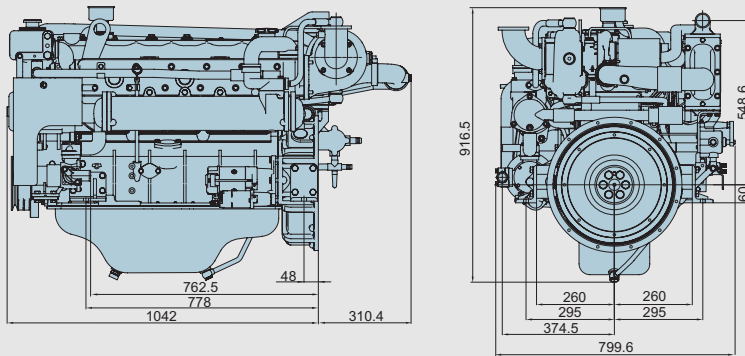

## Performance Curve

· Heavy duty : 132kW(180PS)@2,200rpm

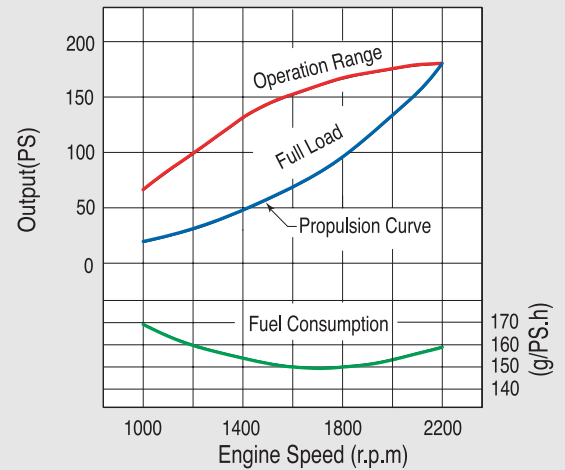

### Marine rating to ISO 3046

#### (1) Heavy Duty

Operation hours are unlimited per year, at average load is up to 90 %, at full load is up to 80 %  
 Typical gearbox ratio: 2.5 ~ 6  
 (Fishing trawler, Tug boat, Pushing vessel, Cargo boat, Freighter, Ferry)

#### (2) Medium Duty

Operation hours are up to 3,000 per year, at average load is up to 70 %  
 At full load is (up to 30 % / 4hrs per 12 hour operation period)  
 Typical gearbox ratio: 2 ~ 3.5  
 (Fishing trawler, Pilot boat, Escort boat, Passenger boat, Freighter, Ferry, Cruising vessel)

#### (3) Light Duty

Operation hours are up to 1,000 per year, at average load is up to 50 %  
 At full load is (up to 20 % / 2hrs per 12 hour operation period)  
 Typical gearbox ratio: 1 ~ 2.5  
 (Light weight fishing boat, Yacht, Cruising vessel, Fast boat, Fire pump)

(Nov.2012)

## Doosan Infracore Engine

21/F, Doosan Tower, 18-12, Euljiro 6-ga,  
 Jung-gu, Seoul, 100-730, Korea.  
 Tel : 82 2 3398 8400  
 Fax : 82 2 3398 8509  
 Email : doosanmarine@doosan.com  
 http://engine.doosaninfracore.co.kr

AUTHORIZED DEALER

\* Specifications are subject to change without prior notice.